

A Broad Portfolio for Multiple Gas Sensor Functions and Design

Meet the Market's Demands

Gore membranes can help you meet increasingly demanding requirements in order to stay competitive:

- increased lifetime
- improved measurement stability
- reduced production costs
- better accuracy
- rapid response time

ePTFE – at the Center Of Our Solutions

ePTFE (expanded polytetrafluoroethylene) continues to set standards, as it offers a wide range of highly desirable attributes (e.g. good uniformity of porosity and pore size) for gas sensors types like EC, NDIR and MOS.

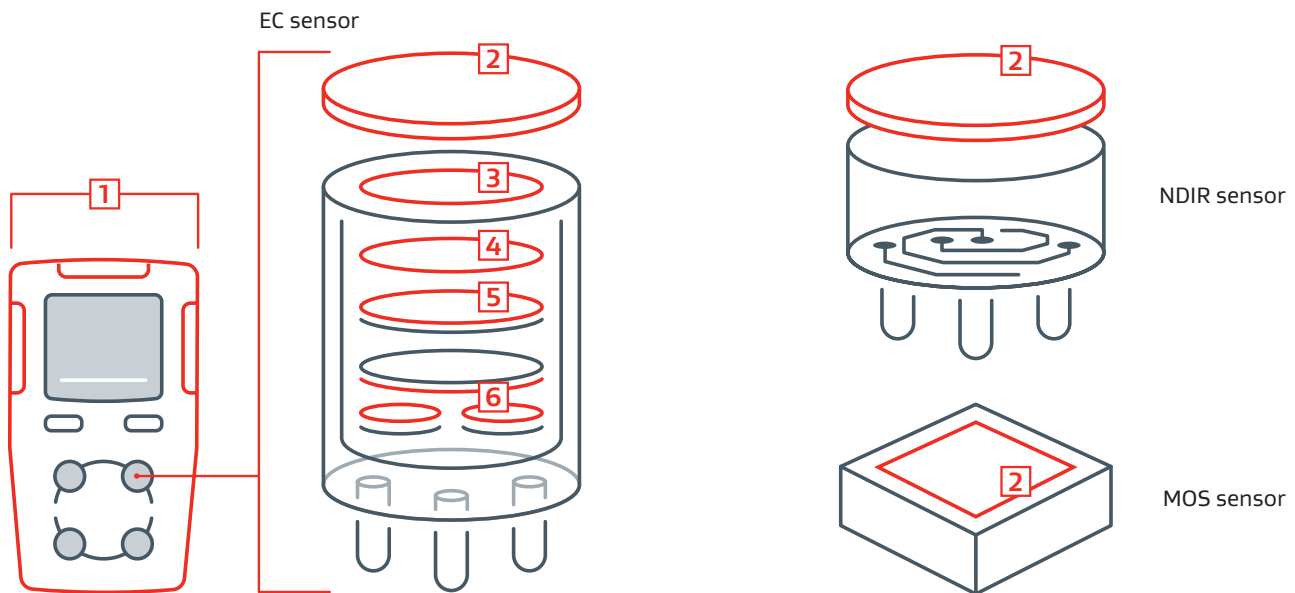

- 1) **Protective vents** – Protects portable or static device from ingress of moisture, particles or other contaminants as a result of condensation, high-pressure cleaning, shocks, vibration or other factors, but allows for gas to go through.
- 2) **Dust cover** – Prevents ingress of dust and liquid, but allows for gas to go through. Provides mechanical protection for exterior of sensor cell.
- 3) **Flow or diffusion control** – Reduces pressure peaks due to rapid change of outside pressure or controls the diffusion of defined gases to measure higher concentrations

- 4) **Sealing ring** – Used as an additional seal within the sensor stack.
- 5) **Membrane at working electrode** – Barrier prevents electrolyte from escaping and allows for gas to go through. Lets gases diffuse at the desired rate and balances pressure differences. Carries the catalyst of the electrode. Chemical resistance required.
- 6) **Membrane at reference and counter electrode** – Carries the catalyst of the electrode. Chemical resistance required.



Gore Gas Sensor Solutions are available in different forms depending on function.

GORE® Protective Vents

for sensing device protection

Adhesive Series	Typical Airflow (ml/min/cm ² @ 70 mbar)	Membrane Type/Characteristic	Membrane Color	IP Rating	Product Form	Thickness (mm)	Dimensions* (mm)	Description	Used as
VE7	290	ePTFE/Oleophobic	Black	IP66 IP68	Adhesive	0.34	2.0 × 5.0** 3.3 × 7.6	high durability PTFE tape	1
VE8	3,300	ePTFE/Oleophobic	White	IP64 IP67	Adhesive	0.26	5.5 × 10.2 8.0 × 14.0 8.9 × 19.1	high flow laminate	1
VE9	1,150	ePTFE/Oleophobic	White	IP66 IP68	Adhesive	0.32	12.5 × 21.5 20.0 × 29.0	high flow high WEP PTFE tape	1

* Standard sizes. Available in various designs and dimensions upon request.

** VE7 & VE8 only

For further information please check the GORE® Protective Vents Adhesive Series Datasheet

for sensor cell protection

Dust Cover	Typical Airflow (ml/min/cm ² @ 70 mbar)	Membrane Type/Characteristic	Membrane Color	IP Rating	Product Form	Thickness (mm)	Dimensions* (mm)	Description	Used as
GDC001	4,310	ePTFE Laminate/hydrophobic	White	IP6X	Cut Part	n.a.	standard dimensions upon request	high flow membrane laminate	2
GDC002	4,310	ePTFE Laminate/hydrophobic	White	IP6X	Adhesive	0.25	standard dimensions upon request	high flow membrane laminate	2
GDC003	> 4,000	ePTFE Laminate/hydrophobic	White	IP6X	Cut Part	0.26	standard dimensions upon request	high flow membrane with grid backer	2

* Available upon project request

GORE® Performance Membranes

for inner sensor cell functions

New Part#		Avg Gurley (s)	Avg Airflow (ml/min/cm ²)	Avg Thickness (µm)	Avg Width (mm)	WEP (bar)	Largest Pore Size (µm)	Shrinkage (%)	Used as
Large Roll	Short Roll								
GPM5600422-L	GPM5600422-S	4,650	1.15	396	140	> 4	n.a.	n.a.	3
GPM4500274-L	GPM4500274-S	3,500	1.5	257	137	> 8	0.03	< 7	5 6
GPM3000165-L	GPM3000165-S	2,300	2.3	156	150	> 3	0.08	< 8	5 6
GPM2400165-L	GPM2400165-S	1,960	2.7	157	156	> 4	0.06	< 7	5 6
GPM2500169-L	GPM2500169-S	1,900	2.8	157	145	> 6	0.04	< 10	5 6
GPM2200117-L	GPM2200117-S	1,450	3.7	107	180	> 2	0.12	< 6	4
GPM0070229-L	GPM0070229-S	40	134	191	210	> 1	1.98	< 6	5 6